

DOORS AND REAR QUARTER

	Page		Page
Door Adjustments—CJ	15-1	Outside Door Handle—CJ	15-2
Door Adjustments—Cherokee-Wagoneer-Truck	15-4	Outside Door Handle—Cherokee-Wagoneer-Truck	15-5
Door Glass—CJ	15-2	Pivot Vent Window—Cherokee	15-9
Door Latch—CJ	15-2	Rear Door Glass	15-8
Door Locking Rod—Cherokee-Wagoneer-Truck	15-6	Rear Door Remote Control and Lock Lever	15-7
Door Rubber Sealer—CJ	15-3	Rear Door Vent Assembly	15-9
Door Trim Panel—CJ	15-1	Rear Window Regulator	15-9
Door Trim Panel—Cherokee-Wagoneer-Truck	15-4	Rear Quarter Trim Panel	15-9
Front Door Glass—Cherokee-Wagoneer-Truck	15-7	Stationary Rear Quarter Window—CJ	15-3
Front Door Vent Assembly—Cherokee-Wagoneer-Truck	15-7	Stationary Vent Window—CJ	15-3
Front Door Window Regulator—Cherokee-Wagoneer-Truck	15-7	Stationary Window—Cherokee	15-10
Hinge Replacement—CJ	15-2	Stationary Window—Wagoneer	15-10
Hinge Replacement—Cherokee-Wagoneer-Truck	15-4	Vent Glass Replacement	15-7
Key Lock—Cherokee-Wagoneer-Truck	15-5	Water Shield—CJ	15-1
Latch and Remote Control—Cherokee-Wagoneer-Truck	15-6	Water Shield—Cherokee-Wagoneer-Truck	15-4
Lock Cylinder Coding—Cherokee-Wagoneer-Truck	15-6	Window Regulator—CJ	15-3

CJ WITH HARDTOP ENCLOSURE

DOOR ADJUSTMENTS

The doors are adjusted at the hinge mounting points on the body or door.

Enlarged holes are provided in the body, lower hinge only, for fore, aft, and tilt adjustments. Enlarged holes are also provided in the door, upper and lower hinges, for up, down, fore, aft, and tilt adjustments.

Prior to any door adjustment or alignment, the door latch must be removed to allow the door to close freely in proper alignment.

The door latch striker should be adjusted in or out to allow the door latch to be fully engaged. The door should be flush with the adjacent body panels.

WINDOW REGULATOR HANDLE

Window regulator handles are attached to the splined shaft of the window regulator with a 5/32-inch Allen head screw. To remove the handle, remove the screw and pull the handle straight off the shaft.

Install the handle with the knob forward, the handle horizontal and the glass all the way up.

DOOR TRIM PANELS

Trim panels consist of fiber board composition covered with a vinyl material. They are fastened to the door with spring clips inserted into holes in the door inner panel.

Removal

(1) Remove screws attaching door assist strap using Torx Bit Tool J-25359-02. Remove strap.

(2) Remove window regulator handle.

(3) Pry trim panel-to-door clips along sides loose with Trim Pad Depressor Tool J-2631-01 and remove panel.

Installation

(1) Position trim panel on door and install clips in hole in inner door panel.

NOTE: To prevent creasing the trim panel cover, do not hammer or exert excessive force on the clips.

(2) Install window regulator handle.

(3) Position door assist strap on trim panel and install attaching screws using Torx Bit Tool J-25359-02.

WATER SHIELD

The water shield is attached to the door inner panel with adhesive. To remove water shield, use a putty knife between shield and door inner panel to break adhesive bond.

When installing water shield, be sure the slit lower portion is tucked inside the door panel at the access opening and that the shield is bonded securely to the door inner panel.

HINGE REPLACEMENT

(1) Mark outline of existing hinge on body and door with wax pencil.

(2) Remove hinge-to-body screws and hinge-to-door screws using Torx Bit Tool J-25359-02 and remove hinge.

NOTE: *Upper hinge is part of windshield hinge assembly. When replacing, adequately support windshield frame prior to removal and check alignment after installation.*

(3) Clean replacement hinge in a suitable solvent and blow dry with compressed air.

(4) Color-coat hinge to match body using Jeep exterior spray paint or equivalent.

(5) Lubricate hinge with Lubriplate or equivalent.

(6) Position hinge on door, align carefully with wax pencil marks, and install screws using Torx Bit Tool J-25359-02.

(7) Position hinge on body, align carefully with wax pencil marks, and install screws using Torx Bit Tool J-25359-02.

(8) Check door alignment. Adjust if necessary (refer to Door Adjustment).

DOOR LATCH REPLACEMENT

(1) Remove screws attaching door latch to door using Torx Bit Tool J-25359-02 and remove latch.

(2) Lubricate door latch with Lubriplate or equivalent.

(3) Position door latch on door and install attaching screws using Torx Bit Tool J-25359-02.

OUTSIDE DOOR HANDLE REPLACEMENT

NOTE: *The replacement outside door handle is furnished without the lock cylinder. The lock cylinder is furnished uncoded without the keys.*

(1) Remove screws attaching outside door handle to door using Torx Bit Tool J-25359-02 and remove handle.

(2) Code existing door lock key to replacement cylinder.

(a) Insert key in replacement cylinder.

(b) File tumblers until flush with cylinder body.

(c) Remove and install key, check that tumblers are flush with body.

(d) Install cylinder in replacement outside door handle.

(3) Install outside door handle on door and install attaching screws using Torx Bit Tool J-25359-02.

DOOR GLASS

Adjustment

One adjustment point is available, regulating the amount of effort required to raise and lower the door glass. The door glass division channel is adjustable fore

and aft at the lower attachment point.

(4) Remove door trim panel and water shield.

(5) Loosen division channel lower adjusting screw and move division channel fore or aft to obtain the desired door glass operation (fig. 15-1).

NOTE: *Movement of division channel fore and aft reduces or increases free play between channels.*

(6) Tighten division channel lower adjusting screw.

(7) Install water shield and door trim panel.

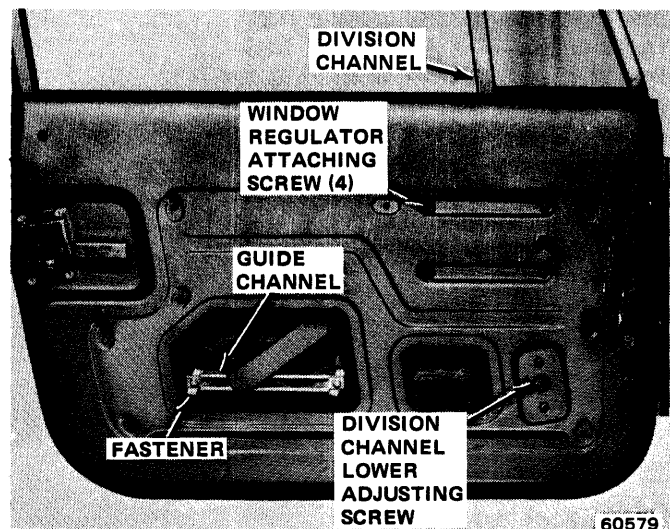

Fig. 15-1 Door Glass Replacement—CJ

Removal

(1) Remove door trim panel and water shield.

(2) Remove glass down-stop.

(3) Remove screws attaching guide channel to plastic fasteners. Remove guide channel and plastic fasteners.

(4) Lower glass to bottom of door.

(5) Remove division channel upper attaching screw and lower adjusting screw. Disengage front three inches of glass weatherstrip from upper door frame. Remove division channel.

(6) Tilt glass toward hinge side of door and disengage from rear channel.

(7) Pull glass up and out of door panel.

Installation

(1) Lower glass into door with front of glass tilted down, while positioning glass into rear channel.

(2) Install plastic fasteners into glass.

(3) Slide glass down into bottom of door panel.

(4) Lower division channel into door and position glass in channel.

(5) Install upper attaching screw and lower adjusting screw. Engage weatherstrip in upper door frame.

(6) Slide guide channel onto regulator arm and position channel on glass. Install attaching screws.

- (7) Install glass down-stop.
- (8) Check operation and adjustment.
- (9) Install water shield and door trim panel.

STATIONARY VENT WINDOW

Removal

- (1) Remove door trim panel and water shield.
- (2) Lower glass to down-stop.
- (3) Remove division channel upper attaching screw and lower adjusting screw.
- (4) Disengage front three inches of weatherstrip from upper door frame. Lower division channel and tilt toward rear of door.
- (5) Remove stationary vent glass from weatherseal.

Installation

- (1) Install stationary vent glass into weatherseal.
- (2) Install division channel into door and position channel on glass.
- (3) Install upper attaching screw and lower adjusting screw.
- (4) Engage weatherstrip in upper door frame.
- (5) Water test and check for leaks.
- (6) If water leakage is evident, apply 3M Windshield Sealer or equivalent or realign weatherseal.
- (7) Check operation and adjustment of door glass.
- (8) Install water shield and door trim panel.

STATIONARY REAR QUARTER WINDOW REPLACEMENT

- (1) Free weatherstrip-to-top flange (on inside of vehicle) by starting at top corner using fingers or wooden wand and pulling weatherstrip down to clear flange while exerting outward pressure on glass.
- (2) Push window and weatherstrip toward outside of vehicle and remove glass.
- (3) Remove weatherstrip from glass and clean off all sealer from glass cavity.
- (4) Before installing glass in weatherstrip, apply a 3/16-inch bead of 3M Windshield Sealer or equivalent in weatherstrip glass cavity using pressure-type applicator.
- (5) Install glass into weatherstrip.
- (6) Lubricate weatherstrip with soapy water.
- (7) Place glass and weatherstrip into position in window opening.
- (8) With weatherstrip-to-top flange in proper position at bottom of window opening, use a wooden wand and walk weatherstrip-to-top flange into position.
- (9) Clean excess sealer from glass with 3M Adhesive Cleaner or equivalent.
- (10) Water test and check for leaks.
- (11) If water leakage is evident between weatherstrip flange, apply 3M Auto Bedding and Glazing Compound or equivalent to affected areas and realign weatherstrip.

DOOR RUBBER SEALER

The door rubber sealer is made of molded latex foam with a smooth rubber skin on the outside.

Plastic retainers are used to retain the rubber sealer to the door below the belt line. Barbs on the retainer depress when inserted in the holes and spread when fully inserted. Above the belt line the sealer is retained in a channel formed in the upper door frame.

Maintenance of Rubber Sealers

Cold weather may cause the rubber sealer to harden and lose resiliency. This may cause the tailgate to loosen in its opening, resulting in noise. When servicing, use a dampened cloth to clean rubber sealer. Clean dirt from all points where the rubber sealer contacts the body. Apply AMC Silicone Lubricant or equivalent to sealer.

CAUTION: *Do not use graphite, brake fluid, or wax on rubber sealer.*

Replacement

Replacement rubber sealers are coated with powder to prevent stickiness in storage. Remove all powder with a dampened cloth before installation.

- (1) Carefully remove rubber sealer from door using needle-nose pliers to remove plastic retainers from panel holes. Remove upper portion from upper door frame with fingers or wooden wand.
- (2) Remove dust and dirt from rubber sealer, door, and body.
- (3) Install upper front corner of sealer to door first using fingers or wooden wand to engage sealer into channel. Place inner shoulder of sealer in channel-to-window frame above belt line.
- (4) Press retainers, starting at rear edge of door, into door panel holes.

WINDOW REGULATOR

Removal

- (1) Remove trim panel and water shield.
- (2) Lower glass to expose guide channel fasteners. Remove fasteners and guide channel. Raise window to full up position and apply masking tape to glass and over top of window frame.
- (3) Remove regulator attaching screws. Remove regulator through access hole in inner door panel.

Installation

- (1) Position regulator in door and install attaching screws.
- (2) Remove masking tape from glass and lower glass.
- (3) Slide guide channel onto regulator arm and position channel on glass. Install attaching screws.
- (4) Check operation.
- (5) Install water shield and door trim panel.

CHEROKEE-WAGONEER-TRUCK

DOOR ADJUSTMENTS

The doors are adjusted at the hinge mounting points on the body or door.

On rear doors, floating plates are located in the body pillars to permit adjustment up, down, in or out. To adjust forward or back, add or remove shims between the hinge and hinge pillar.

On front doors, slotted holes are provided in the hinge for in or out adjustment on the pillars, and up and down and fore and aft or tilt on the doors.

Prior to any door adjustment or alignment, the adjustable striker must be removed to allow the door to close freely in proper alignment without striker interference.

The door lock striker is adjustable up, down, in or out and can be shimmed forward or back to hold the door in the properly aligned position.

The door latch striker should be set so that the latch enters the striker without binding, yet provides secure retention for the lock and prevents up and down or in and out movement of the door.

The striker also should be adjusted in or out to allow the door latch to be fully engaged. The door should be flush with the adjacent body panels.

NOTE: *It is possible to set the striker in so far that the door is closed tight but only the safety catch is engaged. This will prevent locking the door with the key or the pushbutton lock rod.*

DOOR TRIM PANELS

Trim panels consist of fiber board composition covered with a vinyl material. They are fastened to the door with spring clips inserted into holes in the door inner panel and screws along the bottom edge.

Removal

(1) Remove metal overlay strip on armrest, if equipped and remove attaching screws and armrest.

(2) Remove window regulator handle and door latch remote control handle.

(3) Remove trim panel attaching screws on bottom of trim panel.

(4) Pry trim panel-to-door clips along sides loose with Tool J-2631-01 and remove panel.

(5) Loosen setscrew securing remote control mirror control cable to escutcheon, if equipped.

Installation

(1) Insert remote control mirror control cable in escutcheon and tighten setscrew, if equipped.

(2) Position trim panel on door and install clips in holes in inner door panel.

NOTE: *To prevent creasing the trim panel cover, do not hammer or exert excessive force on the clips.*

(3) Install screws along bottom of trim panel.

(4) Install window regulator handle and door latch remote control handle.

(5) Install armrest and metal strip.

WATER SHIELD

The water shield is attached to the door inner panel with adhesive. To remove water shield, use a putty knife between shield and door inner panel to break adhesive bond.

When installing water shield be sure the slit lower portion is tucked inside the door panel at the access opening and that the shield is bonded securely to the door inner panel.

HINGE REPLACEMENT

Front Doors

(1) Remove trim panel and water shield.

(2) Disconnect door speaker wiring, if equipped.

(3) Mark outline of existing hinges on body pillar and door for reference with wax pencil.

(4) Position door in holding fixture.

(5) Remove all hinge-to-body screws.

(6) Remove door from vehicle.

(7) Remove all hinge-to-door screws and remove hinges.

(8) Clean replacement hinges in a suitable solvent and blow dry with compressed air.

CAUTION: *Do not immerse hinge in solvent.*

(9) Color coat hinges to match body.

(10) Lubricate hinges with a Lubriplate or equivalent.

(11) Position hinges on door, being careful to align with scribe marks, install screws. Tighten screws to 25 to 35 foot-pounds torque.

(12) Position door in body opening and align hinges with scribe marks on body pillar. Install and tighten two outside screws, then install and tighten inner screw on each hinge. Tighten screws to 25 to 35 foot-pounds torque.

(13) Remove door holding fixture.

(14) Check door alignment. Adjust if necessary (refer to Door Adjustment).

(15) Connect door speaker wiring, if equipped.

(16) Install water shield and trim panel.

Rear Doors

(1) Mark outline of hinges on body pillar and door for reference with wax pencil.

- (2) Position door in holding fixture.
- (3) Remove all hinge screws and remove hinges. Retain shims.
- (4) Clean replacement hinges in a suitable solvent and blow dry with compressed air.

CAUTION: Do not immerse hinge in solvent.

- (5) Color-coat hinges to match body.
- (6) Lubricate hinges with a Lubriplate or equivalent.
- (7) Position hinges on door with original shims, being careful to align with wax pencil marks, and install screws. Tighten screws to 12 to 18 foot-pounds torque.
- (8) Remove door holding fixture.
- (9) Check door alignment. Adjust if necessary (refer to Door Adjustment).

OUTSIDE DOOR HANDLE

Removal

- (1) Remove door trim panel and water shield.

- (2) Raise window to fully closed position.
- (3) Through opening in inner door panel, remove handle attaching screws and remove handle and gaskets.

Installation

- (1) Position gaskets and handle on door and secure with attaching screws.
- (2) Install water shield and door trim panel.

KEY LOCK

Removal

- (1) Remove rubber sealer along rear edge of door by prying out retaining pins to expose lock cylinder retainer (fig. 15-2).
- (2) Using flat-bladed screwdriver, remove retainer.
- (3) Remove lock cylinder and extension rod from outside of door.

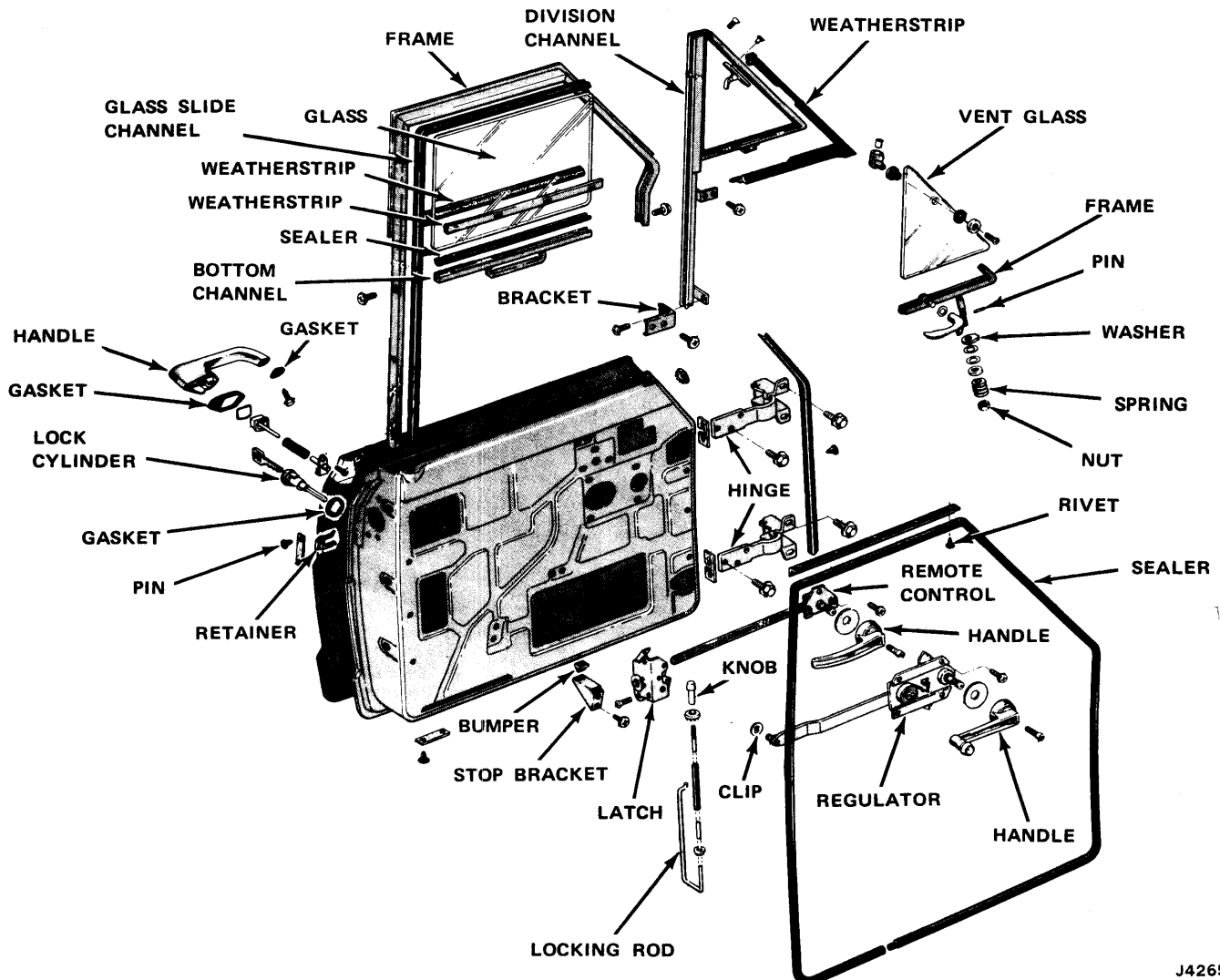

J42654

Fig. 15-2 Front Door—Cherokee-Wagoneer-Truck

Installation

- (1) Position lock cylinder in door, making sure extension rod is inserted in square hole in latch.
- (2) Install lock cylinder retainer.
- (3) Install rubber sealer with retaining pins.

LOCK CYLINDER CODING

The lock cylinder is serviced in a kit which includes an uncoded cylinder, housing, and a dust cover.

Whenever a lock cylinder replacement is required, the uncoded service cylinder can be coded to match the existing key.

- (1) Remove lock cylinder from door.
- (2) Remove dust cover from original lock housing and remove lock cylinder and discard.
- (3) Insert original key into new uncoded service lock cylinder.
- (4) Press cylinder into special Door Cylinder Lock Tumbler Filing Fixture, Tool J-22977, with notched side of key up and long tumbler in slot (fig. 15-3).
- (5) Hold filing fixture in vise and file tumblers flush with flat side of fixture. Use a standard 5/8-inch, double-cut bastard file. Finish filing with smooth mill file.
- (6) Remove lock cylinder from fixture and insert cylinder into opposite end of fixture with notched side of key down (fig. 15-3).

NOTE: This side of the fixture can be identified as the end without the double slot cut out (180° apart).

- (7) File tumblers flush with flat side of fixture.

NOTE: Utilize the filing fixtures as a test gauge. Remove the fixture from the vise and if the tumblers are filed correctly, the lock cylinder will turn in the fixture.

- (8) Insert new lock cylinder into lock housing.
- (9) Install new dust cap and crimp ends of cap over lock housing.
- (10) Install lock cylinder in door.

LATCH AND REMOTE CONTROL

Removal

- (1) Remove door trim panel and water shield.
- (2) Remove lock cylinder.
- (3) Remove screws from door lock remote control (fig. 15-2). Push control in and lower to bottom of door.
- (4) Disconnect remote control arm from door latch and remove remote control assembly through access hole at bottom of door.
- (5) Remove screws attaching door latch to door panel.
- (6) Push door latch in and turn it 90° to free it from lock lever rod and remove through lower access hole.

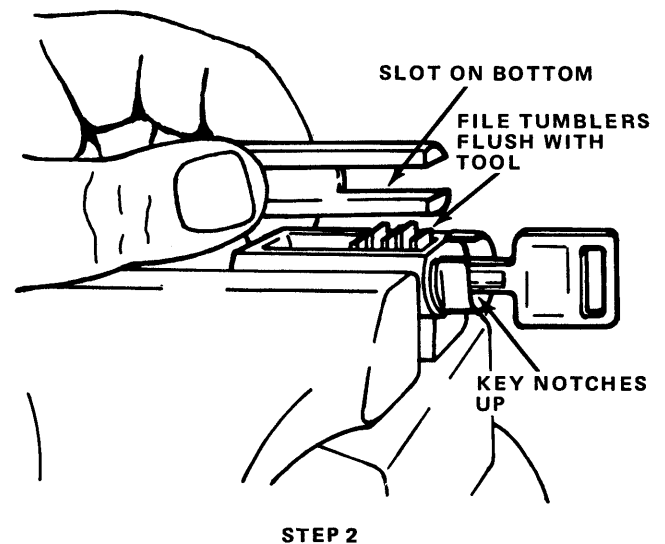
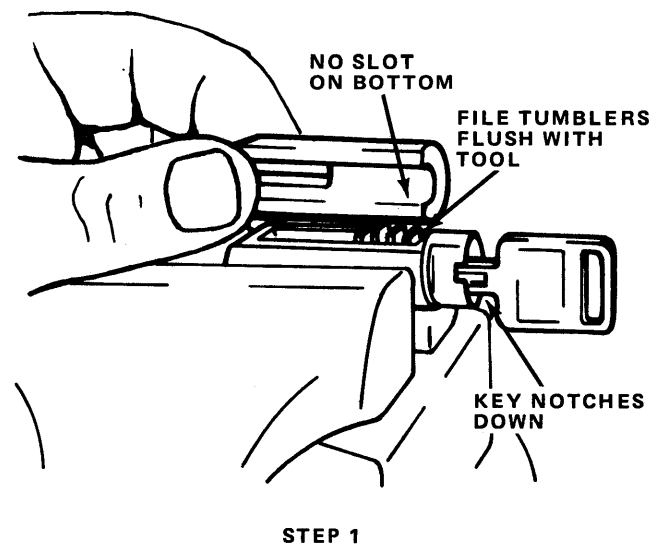

J42655

Fig. 15-3 Filing Lock Tumblers

Installation

- (1) Connect lock lever rod to door latch.
- (2) Position door latch on door panel and install attaching screws.
- (3) Connect remote control arm to door latch. Position remote control on door inner panel and install attaching screws.
- (4) Install outside lock assembly.
- (5) Install water shield and door trim panel.

DOOR LOCKING ROD

Removal

- (1) Remove door trim panel and water shield.
- (2) Remove door lock push knob.
- (3) Push nylon bushing (on rod) off bracket.
- (4) Loosen latch mounting screws and disengage locking rod.

Installation

- (1) Engage locking rod and latch and tighten latch mounting screws.
- (2) Install nylon bushing on bracket.
- (3) Install door lock push knob.
- (4) Install water shield and door trim panel.

FRONT DOOR GLASS**Removal**

- (1) Remove door trim panel and water shield.
- (2) Remove glass stop bracket (fig. 15-2).
- (3) Remove lower division channel attaching bracket.
- (4) Remove division channel upper bracket-to-door panel attaching screws.
- (5) Remove lock rod guide bushing.

NOTE: Move lock rod aside so glass may be lowered to bottom of door.

- (6) Remove screws attaching remote control assembly to door panel and lower to bottom of door.
- (7) Lower door glass and remove retaining clip.
- (8) Lower glass to bottom of door.
- (9) Push lower end of division channel toward front of door to release glass from channel.
- (10) Move glass toward front of door to release it from rear channel.
- (11) Rotate glass vertically 90° and guide it between inner and outer door panels.

Installation

- (1) Position door glass in lower section of door so lifter channel has recessed portion of guide groove toward inner door panel.
- (2) Position glass in rear channel and position front channel so glass can be inserted.
- (3) Slide glass up channels and crank regulator arm down to align pin at end of regulator arm with slot in lifter channel.
- (4) Install retainer on regulator arm.
- (5) Position remote control assembly and install attaching screws.
- (6) Position lock rod and install lock rod guide bushing to door panel.
- (7) Install door lock push knob.
- (8) Install upper and lower division bar attaching brackets.
- (9) Install glass stop.
- (10) Check glass operation.
- (11) Install water shield and trim panel.

FRONT DOOR VENT ASSEMBLY**Removal**

- (1) Remove door trim panel and water shield.

- (2) Remove door window glass.
- (3) Remove upper glass channel.
- (4) Remove vent assembly attaching screws on leading edge of door frame and under base of vent weatherseal (fig. 15-2).
- (5) Move vent assembly toward rear of door, tipping it to clear upper door frame.
- (6) Pull ventilator assembly straight out until upper attaching bracket is above opening between outer and inner door panels.
- (7) Rotate vent assembly 90° to position lower attaching bracket on run channel to clear opening between door panels.
- (8) Remove vent assembly.

Installation

- (1) Position vent assembly in door.
- (2) Install vent assembly attaching screws through door frame.
- (3) Install upper glass run channel.
- (4) Install door window glass.
- (5) Install water shield and door trim panel.

VENT GLASS REPLACEMENT

- (1) Remove screw and washers securing vent glass to upper pivot.
- (2) Remove vent glass from frame.
- (3) Install vent glass in frame.
- (4) Install washers and screw securing vent glass to upper pivot.

FRONT DOOR WINDOW REGULATOR**Removal**

- (1) Remove door trim panel and water shield.
- (2) Lower glass and remove clip attaching regulator arm to glass bottom channel (fig. 15-2).
- (3) Raise and support glass.
- (4) Lower regulator arm and remove attaching screws.
- (5) Remove regulator through access hole in door.

Installation

- (1) Install regulator in door and secure with attaching screws.
- (2) Position regulator arm in glass bottom channel.
- (3) Install retainer clip on regulator arm.
- (4) Remove glass support.
- (5) Install water shield and door trim panel.

REAR DOOR REMOTE CONTROL AND LOCK LEVER ROD**Removal**

- (1) Remove trim panel and water shield.
- (2) Remove door lock push knob.

(3) Remove screws attaching lock control arm to inner door panel.

(4) Remove lock lever rod.

(5) Remove door latch attaching screws.

(6) Disconnect remote control arm and turn latch 90°.

(7) Remove lock lever rod and bellcrank (fig. 15-4).

Installation

(1) Position latch in door and install lock lever rod and bellcrank.

(2) Connect remote control arm to latch and turn latch 90°. Secure latch to door panel with attaching screws.

(3) Install lock lever rod.

(4) Position lock control arm on inner door panel and install attaching screws.

(5) Install door lock push knob.

(6) Install water shield and trim panel.

REAR DOOR GLASS

Removal

(1) Remove door trim panel and water shield.

(2) Remove glass stop bracket.

(3) Remove rear glass channel lower attaching bracket.

(4) Lower door glass to obtain access to retainer clip.

(5) Remove retainer clip, disengage pin from slot in channel and lower glass to bottom of door (fig. 15-4).

(6) Remove inner and outer belt weatherstrips.

(7) Remove upper glass channel.

(8) Remove stationary vent assembly attaching screws (fig. 15-4).

(9) Tilt top of vent assembly forward approximately one inch.

(10) Push lower end of rear glass channel toward

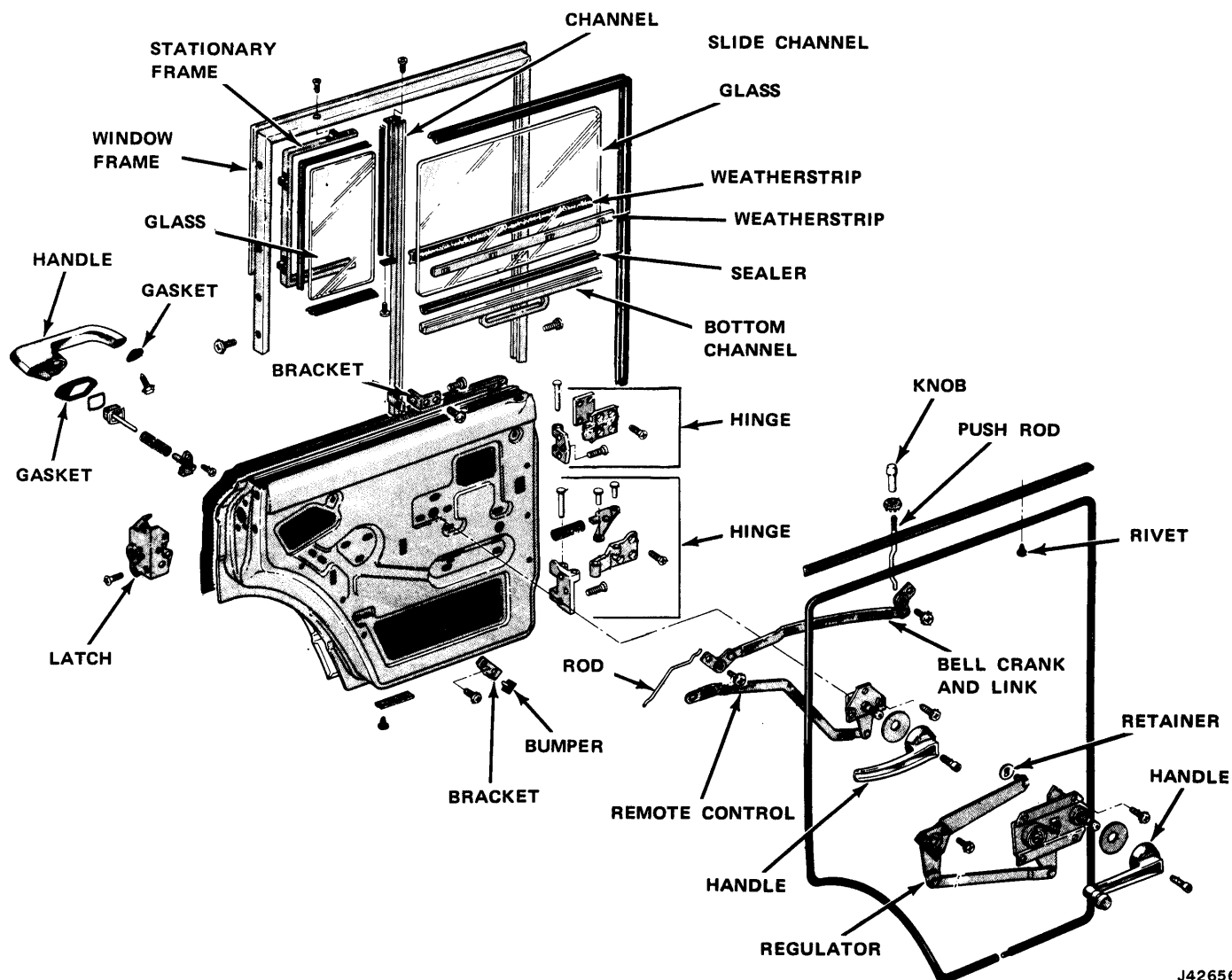

J42656

Fig. 15-4 Rear Door—Cherokee-Wagoneer

rear of door to release glass.

(11) Move glass toward rear of door to release glass from front channel.

(12) Rotate glass 90° and guide glass between inner and outer door panels.

Installation

(1) Position door glass in lower section of door so channel has recessed portion toward inner door panel.

(2) Position door glass in front run channel and push rear channel over glass.

(3) Slide glass up and crank regulator arm down until pin on regulator arm can be inserted in slot of lifter channel.

(4) Install retainer.

(5) Position stationary vent assembly and install attaching screws.

(6) Install upper glass run channel.

(7) Install inner and outer belt weatherstrip.

(8) Install rear channel attaching bracket.

(9) Install glass stop bracket.

(10) Check operation of glass.

(11) Install water shield and door trim panel.

REAR DOOR VENT ASSEMBLY

Removal

(1) Remove door glass.

(2) Apply soap solution under vent weatherstrip and along inner and outer door panels.

(3) Slide vent assembly forward to center of door glass opening.

(4) Push vent assembly down through opening between inner and outer door panels to disengage assembly from upper door frame.

(5) Lower top of vent assembly down to clear upper door frame.

(6) Pull vent assembly straight up until all weatherseal is clear of door panel and vent assembly can be rotated.

(7) Rotate assembly to position lower attaching bracket on channel and pull assembly up and out between panels.

Installation

(1) Install assembly between panels.

(2) Engage vent assembly in upper door frame and slide vent into position.

(3) Install door glass.

REAR DOOR WINDOW REGULATOR

Removal

(1) Remove trim panel and water shield.

(2) Remove regulator arm-to-glass bottom channel retaining clip.

(3) Push regulator pin out of glass channel.

(4) Remove regulator attaching screws and remove regulator.

Installation

(1) Position regulator on inner door panel and secure with attaching screws.

(2) Install regulator pin in glass channel and install retaining clip.

(3) Install water shield and door trim panel.

REAR QUARTER TRIM PANEL

NOTE: *The metal trim panels are held in place with sheet metal screws. Remove all attaching screws to remove panel.*

Removal

(1) Remove ash receiver, holder screws, and holder, if equipped.

(2) Remove armrest metal overlay strip, if equipped, and remove attaching screws and armrest.

(3) Remove trim panel screws at base of panel.

(4) Pry loose trim panel attaching clips along both vertical sides of panel and remove panel.

Installation

(1) Inspect all panel attaching clips; replace any that are bent. To prevent damage to trim panel, do not hammer or exert excessive force on clips.

(2) Install trim panel attaching screws.

(3) Install armrest and armrest metal overlay strip, if equipped.

(4) Install ash receiver holder and ash receiver, if equipped.

PIVOT VENT WINDOW (CHEROKEE)

NOTE: *The glass only can be removed without removing weatherstrip (refer to Vent Window Glass).*

Removal

(1) Remove mylar insert from weatherstrip.

(2) Pull weatherstrip back and remove window frame-to-body screws from inside vehicle (fig. 15-5).

NOTE: *If weatherstrip sticks to body, use a wooden wand and pry loose at one corner.*

(3) Remove window frame and weatherstrip assembly.

(4) Inspect weatherstrip and replace if necessary.

Installation

(1) Lubricate weatherstrip with soap and water solution.

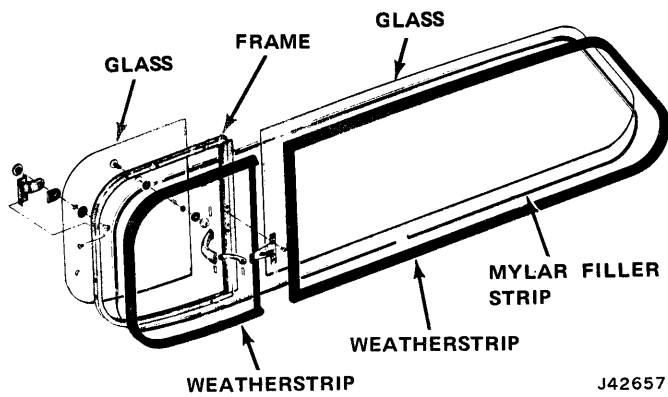

Fig. 15-5 Rear Quarter Window—Cherokee

(2) Place window frame and weatherstrip assembly into position in window opening.

NOTE: Apply 3M Windshield Sealer or equivalent at window frame rear corners.

(3) Using wooden wand, work weatherstrip inner flange into position.

(4) Obtain proper mylar alignment with weatherstrip and work into recess in weatherstrip.

Vent Window Glass

Removal

- (1) Remove handle-to-frame attaching screws (fig. 15-5).
- (2) Remove glass hinge screws and washers.
- (3) Remove glass.

NOTE: If glass sticks to hinges, remove glass by carefully pushing out hinge screw inserts.

- (4) To remove handle assembly from glass, carefully drive out handle assembly-to-stud roll pin.
- (5) Unscrew stud nut and remove stud from glass.

Installation

- (1) Attach glass to frame using hinge screw inserts, washers, and screws.
- (2) Attach handle assembly to frame.
- (3) Attach stud and nut to glass, and connect stud to handle assembly with roll pin.
- (4) Latch window and check for water leaks.
- (5) If water leakage is evident, apply sealant in affected areas.

STATIONARY WINDOW—CHEROKEE-WAGONEER

- (1) Remove interior garnish mouldings from around window and break seal loose between weatherstrip and body panels.
- (2) Push glass toward inside of vehicle.
- (3) Remove weatherstrip from around glass and clean old sealer from glass cavity and flange cavity.

(4) Before installing glass in weatherstrip, apply a 3/16-inch bead of 3M Windshield Sealer or equivalent in glass cavity completely around weatherstrip using a pressure type applicator (fig. 15-6).

(5) With glass installed in weatherstrip and before installing glass and weatherstrip into opening, insert a 1/4-inch cord completely around weatherstrip in flange cavity.

NOTE: The ends of the cord should hang out over the outside surface of the glass approximately in the center of the upper weatherstrip.

(6) Place glass and weatherstrip into position in window opening with ends of cord hanging outside vehicle (fig. 15-7).

(7) Pull on ends of cord to pull lip of weatherstrip over body panel. With cord removed, weatherstrip should be positioned correctly.

(8) Install interior garnish moulding.

(9) Apply bead of 3M Auto Bedding and Glazing Compound or equivalent from outside of vehicle between weatherstrip and body panels.

(10) Clean excess sealer from glass and exterior body surface.

(11) Test window for water leaks.

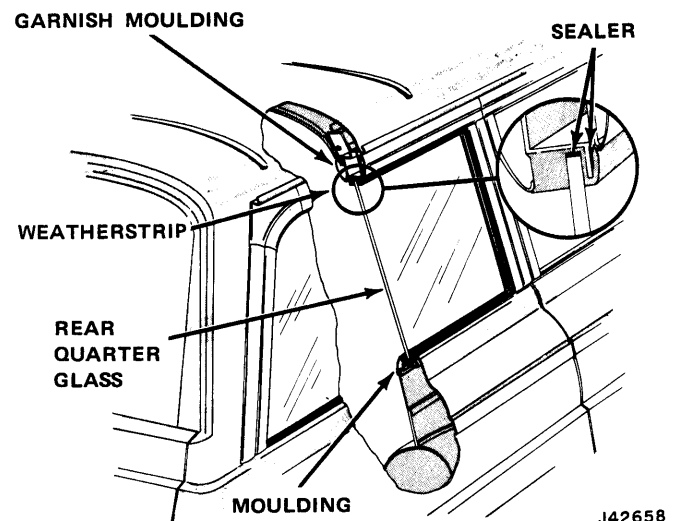

Fig. 15-6 Rear Quarter Window—Cherokee-Wagoneer

STATIONARY WINDOW—CHEROKEE

NOTE: On Cherokee models, the pivoting rear quarter vent window and frame may remain in the vehicle but removal of the mylar filler strip is required to accomplish removal of the stationary window.

- (1) Free weatherstrip-to-body flange (on inside of vehicles) as follows: starting at top corner, using fingers or a wooden wand, pull weatherstrip down to clear flange while exerting an outward pressure on glass.
- (2) Push window and weatherstrip toward outside of vehicle.

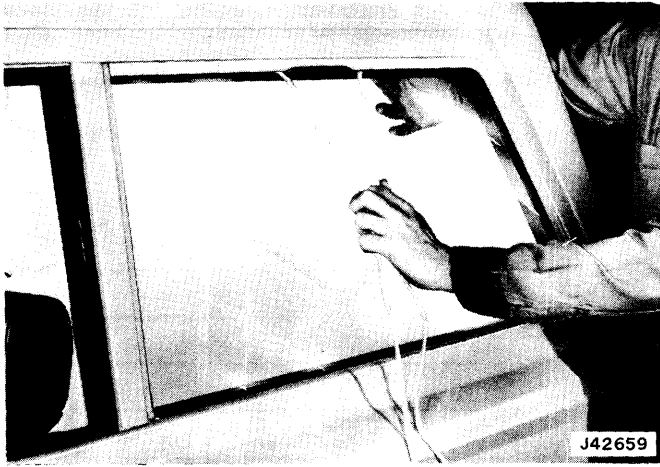

Fig. 15-7 Rear Quarter Window Installation

(3) Remove weatherstrip from glass and clean off sealer from glass cavity.

(4) Before installing glass in weatherstrip, apply a 3/16-inch bead of 3M Windshield Sealer or equivalent in weatherstrip glass cavity using a pressure type applicator.

(5) Lubricate weatherstrip with soapy water.

(6) Place glass and weatherstrip into position in window opening.

(7) With weatherstrip body flange in proper position at bottom of window opening, use a wooden wand and walk weatherstrip-to-body flange into position.

(8) Clean excess sealer from glass.

(9) Check for water leaks.

(10) If water leakage is evident between weatherstrip and flange, apply 3M Auto Bedding and Glazing Compound or equivalent to affected areas and realign weatherstrip.

Special Tools

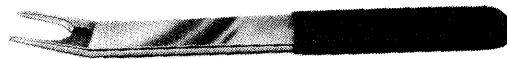

TRIM PAD DEPRESSOR J-2631-01

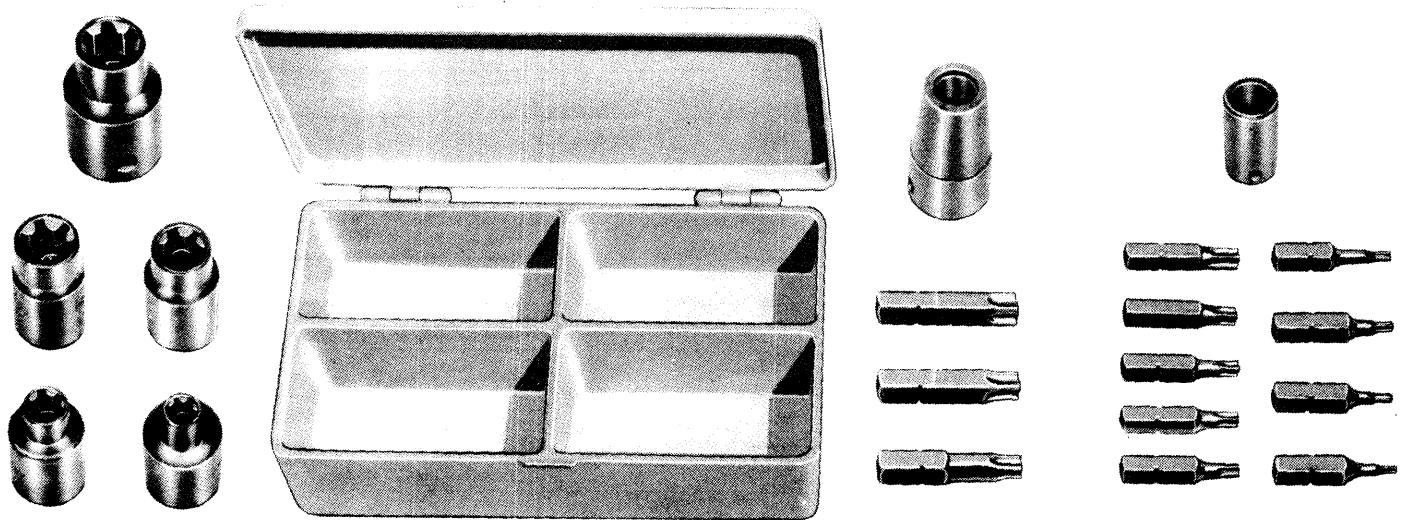

J-25359-02
TORX BIT AND SOCKET SET

